

344 (1960); R. Jessor and D. Silhouette, *Compt. Rend.* **264**, 1123 (1957).

⁶A. J. MacMillan, Laboratory for Insulation Research, Massachusetts Institute of Technology Report No. 172, 1962 (unpublished); K. Kosuge and S. Kachi, *J. Phys. Soc. Japan* **20**, 627 (1965).

⁷D. J. Arnold and R. W. Mires, *J. Chem. Phys.* **48**, 5 (1968).

⁸M. Foëx, *Compt. Rend.* **223**, 1146 (1946); M. Foëx, J. Goldsztaub, R. Jaffrey, R. Lyand, R. Wey, and J. Wucher, *J. Rech. Centre Natl. Rech. Sci. Lab., Bell-evue (Paris)* **21**, 237 (1952).

⁹J. Feinleib and W. Paul, *Phys. Rev.* **155**, 841 (1967).

¹⁰E. D. Jones, *J. Phys. Soc. Japan* **27**, 1962 (1969).

¹¹A. Jayaraman, D. B. McWhan, J. P. Remeika, and P. D. Dernier, Paper II in this series, *Phys. Rev. B* **2**, 3751 (1970).

¹²B. N. Brockhouse, *J. Chem. Phys.* **21**, 961 (1955).

¹³T. R. McGuire, E. J. Scott, and F. H. Grannis, *Phys. Rev.* **102**, 1000 (1956).

¹⁴S. Foner, *Phys. Rev.* **130**, 183 (1963).

¹⁵S. D. Silverstein and I. S. Jacobs, *Phys. Rev. Letters* **12**, 670 (1964).

¹⁶M. G. Foëx and M. Graft, *Compt. Rend.* **209**, 166 (1960).

¹⁷R. M. Moon (private communication).

¹⁸A. Menth, A. C. Gossard, and J. P. Remeika, Proceedings of 1970 Grenoble International Conference on Magnetism, Grenoble, France, 1970 (unpublished).

¹⁹A. C. Gossard, D. B. McWhan, and J. P. Remeika, Paper IV in this series, *Phys. Rev. B* **2**, 3762 (1970).

²⁰P. D. Dernier (private communication).

²¹D. E. Cox, W. J. Takei, and G. Shirance, *J. Phys. Chem. Solids* **24**, 405 (1963).

High-Pressure Nuclear Resonance Study of the Metal-Insulator Transition of V_2O_3

A. C. Gossard, D. B. McWhan, and J. P. Remeika
Bell Telephone Laboratories, Murray Hill, New Jersey 07974
 (Received 24 April 1970)

⁵¹V nuclear magnetic resonance (NMR) has been observed in metallic V_2O_3 at pressures up to 65 kbar at 4.2 °K. Pressures greater than 26 kbar suppress the metal-to-antiferromagnetic insulator transition, leaving V_2O_3 a metal at 4.2 °K. ⁵¹V NMR shows that the metallic phase, unlike the insulating phase, does not order magnetically down to 4.2 °K. The measurements are the highest-pressure resonance measurements which have been reported in the He temperature range. Knight shifts and relaxation times were measured, the Knight shift having an anomalously strong dependence on volume. The relaxation time allows an upper limit of 10^{-13} sec to be placed on the spin fluctuation lifetime of the *d* electrons.

INTRODUCTION

V_2O_3 is one of the few materials which are known to exhibit a temperature-induced insulator-metal transition.¹ The low-temperature insulating phase is antiferromagnetic,² but the magnetic character of the metallic phase is not clear. Recently it has been found that the addition of 1% Cr_2O_3 to V_2O_3 results in a first-order transition with no change in long-range order from metallic (M) to insulating (I) properties at room temperature.³ Pure V_2O_3 must then be considered as part of a more general phase diagram consisting of surfaces for a metal-paramagnetic insulator (M-I) transition and for a metal-antiferromagnetic insulator transition (M-AF) as a function of temperature, pressure, and composition. For $x \gtrsim 0.02$ in $(V_{1-x}Cr_x)_2O_3$, there is a purely magnetic (AF \rightarrow I) transition as a function of temperature. The M-I transition has been interpreted as a Mott transition.⁴ In order to elucidate the mechanism of this transition a more complete characterization of the magnetic properties of the metallic phase is necessary.

At 1 atm it is not possible to study the metallic phase at very low temperatures because of the M-AF transition, but at pressures in excess of ≈ 26 kbar the AF phase of V_2O_3 is suppressed.⁵ If there were local moments in the metallic phase they should order magnetically at low temperatures. Studies of the electrical resistivity as a function of temperature at pressures above 26 kbar did not reveal any anomalies which could be associated with magnetic ordering.⁵ These are only indirect measurements of the magnetic character of metallic V_2O_3 , so it was decided to study the ⁵¹V nuclear magnetic resonance (NMR) at high pressure and low temperature. These measurements detect the very sizable ($\sim 10^5$ Oe/ μ_B) hyperfine fields resulting from magnetic ordering and thus provide a direct and critical test of the magnetic character. In addition, it is possible with this technique to measure the effect of the imaginary parts of the electronic susceptibility on nuclear relaxation.

In the present paper, the techniques necessary to do nuclear magnetic measurements at 4.2 °K and pressures in excess of 26 kbar are described. Evi-

dence will be presented to show that no magnetic order occurs in the metallic state down to 4.2 °K and that the material must thus be described from a band point of view. Nuclear relaxation measurements are used to estimate the lower limit on the bandwidths.

I. EXPERIMENTAL

For simultaneous low-temperature high-pressure experiments the pressure transmitting medium which is closest to true hydrostatic conditions is solid He. However, a practical pressure limit is set at ≈ 10 kbar by the occurrence of leaks in the pressure system. In order to reach the pressures of interest for the present experiment it was necessary to use a supported multianvil device and a solid pressure transmitting medium. A conventional girdle die employing AgCl as the pressure transmitting medium was used. The whole device was then mounted in a cryogenic press capable of delivering 300 tons to a chamber at 4.2 °K. Part of the experimental apparatus is shown in Fig. 1. The magnetic field is produced by a split-coil superconducting solenoid which is capable of reaching 10 kG. In order to produce a homogeneous magnetic field at the sample, the high-pressure die was constructed of nonmagnetic components. The support rings are made of Discaloy and the tungsten carbide was Kennametal 601 (anvils) and 602 (girdle). K 601 is a binderless carbide which is very difficult to use because of its brittle nature. To improve slightly the lifetime of the die, K 602 which contains 0.5% Cr binder was used in the girdle.

The powdered V_2O_3 was made from high-purity V_2O_5 supplied by Johnson Matthey. The total cation impurity content of the V_2O_3 was determined by emission spectrographic analysis to be less than 5 ppm. The powdered V_2O_5 was placed in a Pt boat in an atmosphere-controlled tube furnace. The temperature was slowly raised to 1000 °C in a

stream of hydrogen over a period of 24 h. The furnace was maintained at 1000 °C for 16 h. The furnace power was turned off and the sample allowed to cool to room temperature. The resulting V_2O_3 was checked by powder x-ray diffraction analysis, and it was found to be single-phase material with lattice parameters in agreement with those found in other studies.⁶

The sample and coil arrangement are shown in the inset of Fig. 1. A description of the multianvil cryogenic high-pressure device has been given elsewhere.⁷ From the point of view of the NMR studies, one would like to have the largest possible sample. On the other hand, from the high-pressure point of view one would like a small sample immersed in a large volume of the pressure transmitting medium in order to minimize the pressure gradients and to obtain a reliable pressure calibration. As a compromise, a coil of 0.05 cm³ was used and encased in 0.22 cm³ of AgCl. The sample was slightly compacted in a mold and then GE 7031 adhesive was allowed to soak into the compact in order to give mechanical stability and to separate the sample particles. This procedure was found sufficient to keep enough of the V_2O_3 particles electrically insulated from one another to allow penetration of the rf field into the sample. The 25–30-turns coil of 0.13-mm-diam insulated copper wire was wound around the sample. After coating with GE 7031, the assembly was fitted between AgCl disks which were cut out to hold the sample. The axis of the coil was perpendicular to the magnetic field. The ends of the coil were wrapped around 0.13-mm gold-plated Mo wire leads which passed through the pyrophyllite gasket and were then soldered to a coaxial cable which came out of the cryostat.

In order to calibrate the pressure against the load applied to the high-pressure die, a bismuth wire was mounted axially in the cell next to the sample and a two-lead electrical resistivity measurement made across the anvils. The transition at 25.5 kbar⁷ was observed at room temperature and a linear calibration at all temperatures was assumed. It is known that AgCl becomes brittle at low temperatures, and it is not clear that the pressure calibration is the same at low temperature and at room temperature. Indirect evidence can be obtained from earlier work on the suppression of the transition in V_2O_3 . In the earlier studies, the phase diagram was determined by repeated cycling through the transition as the apparatus was cooled to 4.2 °K and warmed again.⁵ In a separate run the pressure was advanced at room temperature to just above the critical pressure (≈ 26 kbar), and then the apparatus was cooled to 4.2 °K and cycled through the transition. The transition was observed at similar applied loads in each experiment so the

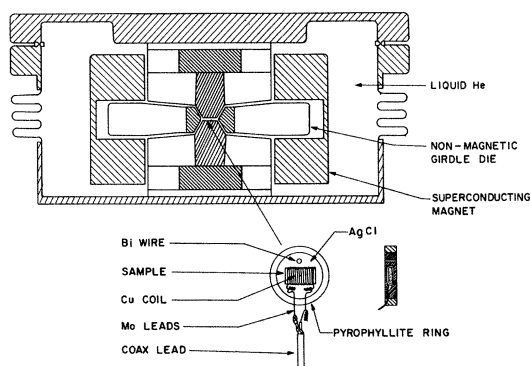

FIG. 1. Schematic diagram of the liquid-helium-cooled high-pressure press, superconducting magnet, and sample cell for nuclear resonance measurements.

effects of the embrittling of the AgCl cannot be too great. However, in the present work, there must be pressure gradients because of the large sample, and the NMR will result from nuclei subjected to a distribution of pressures.

The nuclear resonance was observed by use of a single-coil coherent pulsed spectrometer, the ^{51}V free-induction decay signal being observed at a frequency of 6.9 MHz. With transmitter pulses of 200-W peak rf power, a maximum free-induction signal resulted from pulses of 3- μsec duration. The integrated amplitude of the initial free-induction signal on repetitive pulsing was stored in a boxcar integrator and was recorded as a function of magnetic field. In later experiments, the ^{51}V spin echo following a pair of transmitted pulses was also measured and recorded. Spin-lattice relaxation measurements were made by measuring the recovery of the free induction and echo signals following a train of 1 to ~ 100 rapidly repeated saturating pulses. The pulse technique was especially suitable to the high-pressure measurements since it obviated the need of bringing separate field-modulation coils in the already crowded geometry of the cryostat, and since the use of the short 200-W pulses enabled a width $\Delta\omega \sim 1/\tau \sim 300$ kHz of the spectrum to be covered with each pulse.

The magnet was calibrated by observing the ^{27}Al resonance in Al filings both at 1 atm and 10 kbar as a function of field. This calibration was performed on two different samples with no change within experimental error. As a further check on the calibration, one sample of V_2O_3 was run together with Nb as a field marker. Using the Al resonance calibration of the magnet, the 26-kbar Knight shift of ^{93}Nb in Nb metal was observed to be $+1.01 \pm 0.20\%$ in comparison with its atmospheric pressure value of $+0.85\%$.

II. RESULTS

In the first experiment the pressure was increased to 26 kbar at room temperature and the system was then cooled to 4.2 °K. The ^{51}V nuclear resonance was observed by free-induction decay. The pressure was decreased and the intensity of the resonance decreased until it was no longer observable at ≈ 13 kbar (see inset Fig. 2). With a new sample of V_2O_3 plus Nb, the pressure was then increased slowly up to ≈ 65 kbar and the shift in the resonant frequency followed as a function of pressure by sweeping through the resonance with field. The load was then released slowly to ≈ 25 kbar and the frequency shift with pressure was found to be reversible. After holding 48 h at 25 kbar the apparatus was recooled to 4.2 °K and the pressure cycled up to ≈ 65 kbar and back again. Cracking sounds which are usually associated with the partial failure of the tungsten carbide were heard during the first release

of pressure from 65 kbar. If the die had cracked then it is probable that the pressure calibration would change. However, the die is more efficient on a recycling of the pressure in that it takes a smaller applied load to reach the Bi *I-II* transition. Since it is not possible to account for these opposite effects accurately, the data from the second pressure cycle to 65 kbar are plotted using the same

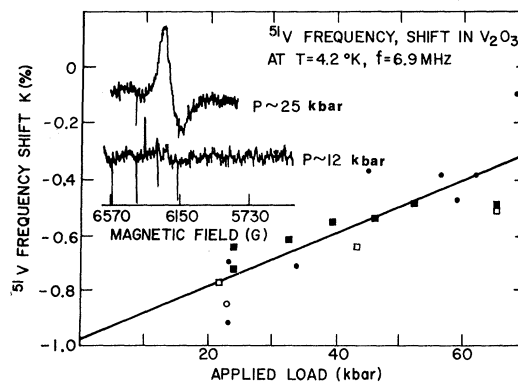

FIG. 2. ^{51}V frequency shifts in V_2O_3 at $T = 4.2^\circ\text{K}$ and $f = 6.9$ MHz. Circles and squares refer to measurements taken, respectively, on the initial application of load and on a second application of load two days later. Closed data points refer to measurements made with increasing load and open data points to measurements with decreasing load. A later measurement on a third sample using spin-echo amplitude measurements at 26 kbar gave $K(26 \text{ kbar}) = -0.92\% \pm 0.20\%$. The calibration of the load was obtained from the 25.5-kbar transition of bismuth on the initial loading, as described in the text. During the second loading (square data points) it was noted that the bismuth transition was reached under $\sim 20\%$ less load than on the initial loading. For this reason, the pressure on the V_2O_3 sample in the 20- to 30-kbar regime is as much as 5 kbar greater than indicated for the square points. Conversely, in the regime above 50 kbar, cracking of the girdle may have resulted in a reduction of pressure. Correction for these two effects would raise the already anomalously high slope shown for the frequency shift versus pressure. It is also probable that in the presence of pressure inhomogeneities in the 20- to 30-kbar regime the portions of the sample in the higher-pressure regions would contribute more strongly to the observed resonance than would those portions of sample in lower-pressure regions. This phenomenon would result from the rapid falloff in resonance intensity at low pressures demonstrated in Fig. 3 and in the inset of this figure. For this reason, also, the data points in the 20- to 30-kbar regime may represent pressures up to 5 kbar greater than shown. Consideration of such a correction would also increase the frequency-shift-versus-pressure slope. The inset of the figure shows free-induction-decay nuclear-resonance amplitudes as measured with phase-coherent detection at 25 and 12 kbar. The greatly reduced amplitude at 12 kbar results from the fact that the sample is antiferromagnetically ordered at this pressure, and the nuclear resonance is consequently shifted out of the region of observability to a much higher frequency.

pressure calibration. The ^{51}V frequency shifts (relative to a reference gyromagnetic ratio⁸ of 1.1193 kHz/G) as a function of pressure are shown in Fig. 2. The estimated accuracy of the Knight-shift measurements is $\pm 0.20\%$. The intensity of the resonance as a function of pressure is shown in Fig. 3. The break in the curve at 26 kbar is interpreted as arising from the transition from the nonmagnetic to magnetic state with decreasing pressure. The earlier resistivity measurements showed a sharp transition as a function of pressure at 4.2 °K. It is assumed that the width of the transition to zero intensity reflects the large pressure gradients in the present experiment with decreasing pressure.

The width of the ^{51}V resonance response between half-power points of spin-echo amplitude tracings was (300 ± 50) G at a pressure of 26 kbar. This width is apparently the result of either an inhomogeneous magnetic field or frequency-shift distribution resulting from pressure inhomogeneities. Measurement of the width from the free-induction-decay tracings was more difficult because of the oscillations in the recorded tracings resulting from the phase coherent mode of detection.

The decay of the spin-echo amplitude gave an approximate dynamic microscopic phase-memory time T_2 of (20 ± 5) μsec at 26 kbar. This is approximately 20 times longer than the static macroscopic phase-memory time associated with the linewidth of 300 G and confirms that the observed linewidth results from inhomogeneous, rather than dynamic, broadening. The value of T_2 is of the order expected from nuclear dipolar interactions.⁹ This indicates that there are no indirect nuclear exchange (Ruderman-Kittel) interactions¹⁰ significantly greater than the dipolar interaction present, since the motional narrowing effect of such nuclear exchange inter-

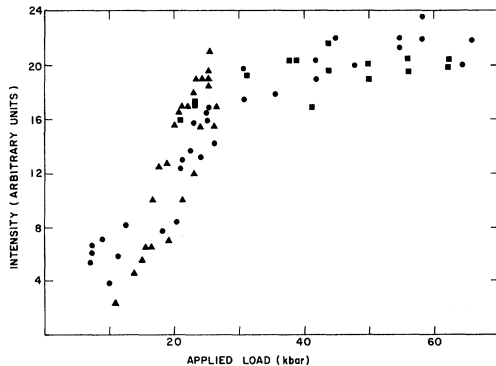

FIG. 3. Intensity of the nuclear-resonance free-induction-decay amplitude versus applied load at 6.9 MHz and $T = 4.2$ °K. The triangles refer to an initial loading to 26 kbar, the circles to a loading of a new sample to 65 kbar, and the squares to a first loading two days later.

actions would be to lengthen T_2 beyond the normal dipolar value.¹¹ Further, as will be shown later, the observed T_2 is much too short to result from nuclear spin-lattice relaxation. The spin-lattice relaxation-time measurement of the recovery of the signal following saturation of the resonance was restricted in accuracy by the limited signal to noise and by difficulty in saturating the entire ^{51}V resonance spectrum. A recovery time of 5 msec was measured, but it is felt that this is a lower limit on the true T_1 . This is because equilibration of the level populations involved in transitions near the center of the resonance profile would be expected to occur faster than equilibration of the entire set of nuclear states.¹² It is probable that the measured rate is accurate within one order of magnitude. In any event, the limit $T_1 \gtrsim 5$ msec is more than two orders of magnitude longer than T_2 , and confirms that spin-lattice relaxation is not an important contribution to the T_2 process.

III. INTERPRETATION

Because of the hyperfine interaction $A_d \vec{I} \cdot \vec{S}^d$ between the nuclear spins \vec{I} and the d -electron spins \vec{S}^d , the NMR gives information about the spin magnetization $\vec{S}^d(q, \omega)$. An especially sensitive test is provided for static ($\omega = 0$) configurations of magnetic ordering in that magnetically ordered d -electron spins $\langle S_z^d(q_0, 0) \rangle$ would shift the nuclear resonance frequency by $\sim A_d \langle S_z^d(q_0, 0) \rangle / h$. For¹³ $A_d/h = 3 \times 10^8 \text{ sec}^{-1}$ and $\langle S_z^d(q_0, 0) \rangle = 1$, this is a frequency shift of ~ 300 MHz. The fact that ^{51}V resonance is observed at 4.2 °K in metallic (high-pressure) V_2O_3 with a shift and linewidth $\sim 10^3$ times smaller than 300 MHz is the most important result of the present investigation, and puts an upper limit of $\sim 10^{-3} \mu_B$ on any statically ordered moments under the experimentally observed conditions.

In order to make a more detailed interpretation of the nuclear-resonance frequency shifts and linewidths, we may partition the magnetic susceptibilities and the frequency shifts into component parts.^{13, 14} The susceptibility can be expressed as

$$\chi(T) = \chi_d(T) + \chi_{\text{VV}} + \chi_{\text{dia}}$$

and the frequency shift can be expressed as

$$K(T) = K_d(T) + K_{\text{VV}} + K_{\text{dia}}$$

$$= \alpha_d \chi_d(T) + \beta' \chi_{\text{VV}}$$

$\chi_d(T)$ refers to the temperature-dependent d -spin susceptibility, χ_{VV} refers to the Van Vleck field-induced paramagnetism, and χ_{dia} refers to the ion core and orbital diamagnetism. For reasons which will be detailed in the following discussion of the pressure dependence of the frequency shifts, it is felt that the Van Vleck and diamagnetic terms are substantially pressure independent. They may be

taken to have the same values at high pressure as were estimated by Jones for 1 atm,¹³ namely, $\chi_{VV} \approx 210 \times 10^{-6}$ emu/mole (of $\text{VO}_{1.5}$), $\chi_{dia} \approx 0$. The temperature and pressure dependence of the susceptibilities and frequency shifts evidently result primarily from the d -spin terms. Figure 4 shows the deduced temperature and pressure variation of the d -spin term of the frequency shift in a three-dimensional plot. The d -spin susceptibility is then proportional to the d -spin frequency shift. The shaded surface indicates the transition to the insulating antiferromagnetic state, where the resonances become unobservable. It is seen that in the high-pressure regime studied here the resonance frequency shifts lie in the same range as the higher-temperature 1-atm values.¹³

The pressure dependence of the frequency shift is quite strong, however. The slope of K versus P shown in Fig. 2 is $dK/dP = 0.0095 + 0.0050\%/kbar$. Taken with a value of the bulk compressibility¹⁵ $d \ln V/dP = 2140 \pm 500$ kbar⁻¹, it yields the unusually large value of $d \ln K/d \ln V = 19 \pm 10$. Expressing K as $K = \alpha_d \chi_d + \beta \chi_{VV}$, we isolate the only significant factor in producing the observed volume dependence by noting that the volume dependence of the three factors, A_{orb} , χ_{VV} , and A_{d-spin} , can only be of order unity. This is because (i) A_{orb} is proportional to the mean value of r^{-3} for the $3d$ wave functions,¹⁶ so would not be expected to vary more strongly than the volume; (ii) χ_{VV} , as mentioned above, depends on the over-all features of all the degenerate bands, so would also vary approximately as the volume; and (iii) measured values of A_d in V and in the ferromagnetic transition metals vary only roughly linearly in volume.¹⁷ We thus deduce that the volume dependence of the d -spin susceptibility χ_d is primarily responsible for the large pressure and volume dependence of the Knight shift. Hence,

$$\frac{d \ln \chi^{spin}}{d \ln V} \approx \frac{d \ln K^{spin}}{d \ln V} \approx \frac{K}{K^{spin}} \frac{d \ln K}{d \ln V} \approx 8 \pm 5.$$

This value for $d \ln \chi_d/d \ln V$ is larger than the usual value near unity found in most other metals. For comparison, a value of 0.8 is found for V metal.¹⁸ Apparently, metallic V_2O_3 is very nearly critical with respect to forming a magnetic state and as a result the susceptibility is strongly volume dependent. It is, however, definitely not yet magnetically ordered, as indicated above by the absence of any frequency shifts of the order of 300 MHz.

In view of the absence of ordering, it is apparent that V_2O_3 must be described by an unmagnetized band in the high-pressure metallic state at 4.2 °K. An estimate of the minimum electron spin fluctuation frequency ω_f can be obtained from the nuclear relaxation rates. In the absence of exchange enhancement and for $kT < \hbar \omega_f$, one expects the nu-

clear spin-lattice relaxation rate to be of order¹⁹

$$(T_1)^{-1} \sim A^2 kT / \hbar^3 \omega_f^2.$$

From the experimental result $(T_1)^{-1} \leq 200$ sec⁻¹ at 4.2 °K and $A/\hbar = 3 \times 10^8$ sec⁻¹, we find that $\hbar \omega_f \gtrsim 300$ °K.

A consistent estimate of $\hbar \omega_f$ can also be obtained from the static spin susceptibility. One expects

$$\chi^{spin} \sim \mu_B^2 / \hbar \omega_f$$

for a band which may be exchange enhanced.²⁰ For $\chi^{spin} = 12.3 \times 10^{-6}$ emu/g, we obtain $\hbar \omega_f \sim 400$ °K in order-of-magnitude agreement with the estimate from nuclear relaxation.

The pressure dependence of the resonance frequency shift at 4.2 °K implies that the resonance frequency shift may also be somewhat pressure dependent at $T > 170$ °K. From observations at 170 °K,¹³ however, there is unfortunately no means of distinguishing between localized magnetic moments and spin fluctuations with frequency below kT/\hbar . The significance of the present work is that the metal-to-insulator transition can occur at low temperature between a high-pressure metallic state which unambiguously is paramagnetic and a lower-pressure antiferromagnetic-insulating state.

It is interesting to compare the properties of me-

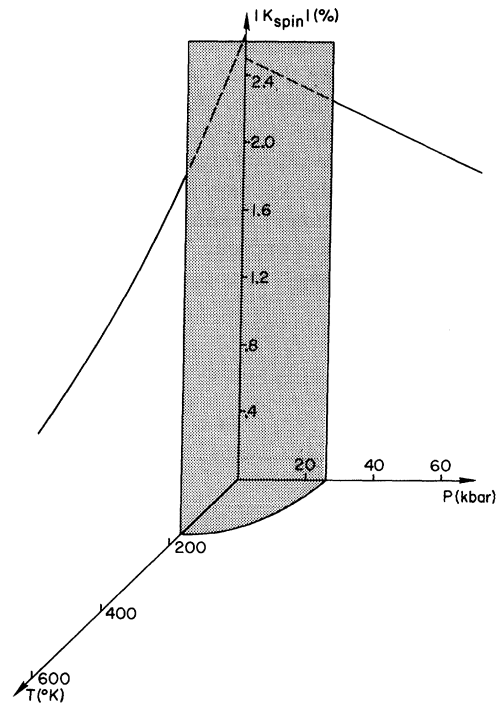

FIG. 4. d -spin components of ^{51}V NMR frequency shifts as a function of pressure at $T = 4.2$ °K and as a function of temperature at $P = 1$ atm. The solid lines are linear and Curie-Weiss fits, respectively, of the data. The broken lines are continuations of the fits in the anti-ferromagnetic region where no resonances were observed.

tallic V_2O_3 with those of V metal. As seen above, the d -spin frequency shift varies from -1.8 to -2.3% under the experimental conditions for V_2O_3 , and, from the hyperfine coupling constant used above, corresponds to a d -spin susceptibility of 9.6×10^{-6} to 12.3×10^{-6} emu/g. (In making this correspondence, we should note that the proportionality of the d -spin Knight shift and d -spin susceptibility occurs even though the d -spin Knight shift results from some combination of core polarization, conduction electron polarization, and unquenched orbital polarization effects. We require only that these several contributions preserve their relative contributions to the d -spin Knight shift as the temperature or pressure is varied.)

Comparisons should also be made with other vanadium oxides. Vanadium "monoxide," although originally reported to undergo a metal-insulator transition similar to that of V_2O_3 , has now been shown to have no transition for compositions ranging from $VO_{0.79}$ to $VO_{1.30}$.²¹ Nuclear resonances were observed in samples of composition $VO_{0.86}$, $VO_{1.02}$, and $VO_{1.23}$ between 1.4 and 300 °K with no evidence of a sharp transition.²² A frequency shift of $+0.4\%$, independent of composition and temperature, was observed. A resonance linewidth increasing with O content and decreasing temperature was found, however, and interpreted in terms of increased susceptibility on a minority of V atoms with few V neighbors. The suppression of magnetism by the presence of V near neighbors is consistent with the pressure reduction of the spin susceptibility of V_2O_3 inferred above. The VO Knight shifts are somewhat more positive than any observed in V_2O_3 . The magnetic site VO nuclear resonances were not observed, however.

VO_2 , which shows a first-order metal-insulator transition at ~ 345 °K, has also been studied.²³ Umeda, Ashida, Kusumoto, and Narita observed nuclear resonance above and below this transition, demonstrating that there was no onset of magnetic ordering at the transition.²⁴ They further discovered an intermediate first-order structural trans-

formation at ~ 325 °K. In the insulating state, the ^{51}V frequency shift was $+0.28\%$ and in the metallic state the shift was -0.38% , reflecting a sevenfold increase in magnetic susceptibility²⁵ on passing from the insulating to metallic states. The VO_2 nuclear resonance was observed in this laboratory down to $T = 1.7$ °K, indicating no magnetic ordering to this temperature. The metallic range shift lies in the same range as the V_2O_3 shifts, and the metallic susceptibilities of VO_2 and V_2O_3 are very similar.

CONCLUSIONS

The most important result of this study is that a nuclear-resonance signal is observable in metallic V_2O_3 at 4.2 °K with a relatively small frequency shift and linewidth. This reveals immediately that the metallic state does not order magnetically and that the transition from insulator-to-metal is accompanied by a transition from localized magnetic moment behavior to band magnetism. It thus precludes superlattice spin-density wave states in the metallic state at $P > 26$ kbar, as might occur in Kohn's theory of the Mott transition.²⁶ Whether the band mass is enhanced by polaron formation and whether exchange enhancement is important is not resolved, although in either case a lower limit of 10^{13} sec⁻¹ or ~ 300 ° can be placed on the spin fluctuation frequency. The strong dependence of the susceptibility on volume for metallic V_2O_3 might result either from a strongly volume-dependent state density or strongly volume-dependent exchange enhancement. Again, the resonance results do not determine the choice between the two possibilities.

ACKNOWLEDGMENTS

We wish to acknowledge helpful discussions and suggestions from T. M. Rice, M. Weger, W. F. Brinkman, and A. M. Clogston, and the expert technical assistance of A. L. Stevens and J. B. Mock.

¹M. Föex, Compt. Rend. 223, 1126 (1946); D. Adler, *Solid State Physics*, edited by F. Seitz and D. Turnbull (Academic, New York, 1968), Vol. 21, p. 1.

²R. M. Moon, J. Appl. Phys. 40, 1445 (1969).

³D. B. McWhan, T. M. Rice, and J. P. Remeika, Phys. Rev. Letters 23, 1384 (1969).

⁴N. F. Mott, Proc. Phys. Soc. (London) 62, 416 (1949).

⁵D. B. McWhan and T. M. Rice, Phys. Rev. Letters 22, 887 (1969).

⁶George Andersson, Acta Chem. Scand. 8, 1599 (1954); D. B. McWhan and J. P. Remeika, Paper I in this series, Phys. Rev. B 2, 3734 (1970).

⁷D. N. Lyon, D. B. McWhan, and A. L. Stevens, Rev. Sci. Instr. 38, 1234 (1967); D. B. McWhan, T. M. Rice, and P. H. Schmidt, Phys. Rev. 177, 1063 (1969).

⁸H. E. Walchli and H. W. Morgan, Phys. Rev. 87, 541 (1952).

⁹J. H. Van Vleck, Phys. Rev. 74, 1168 (1948).

¹⁰M. A. Ruderman and C. Kittel, Phys. Rev. 96, 99 (1954).

¹¹B. G. Silbernagel, M. Weger, W. Gilbert Clark, and J. H. Wernick, Phys. Rev. 153, 535 (1967).

¹²R. E. Walstedt, Phys. Rev. Letters 19, 146 (1967); 19, 816 (1967).

¹³E. D. Jones, Phys. Rev. 137, A978 (1965). Jones observed ^{51}V NMR in metallic V_2O_3 at 1 atm between 170 and 500 °K. A value of $A_d/\hbar = 3 \times 10$ sec⁻¹ was determined by Jones from comparison of the metallic state resonance frequency shifts with the temperature dependence of the magnetic susceptibility below 300 °K. Below 170 °K, the

resonance was observed to disappear, which Jones correctly attributed to antiferromagnetism. At temperatures above 300 °K [E. D. Jones, *J. Phys. Soc. Japan* **27**, 1692 (1969)] an anomaly was noted in that the resonance frequency shifts no longer varied proportionally with the susceptibility. We believe [A. Menth and A. C. Gossard, Proceedings of 1970 Grenoble International Conference on Magnetism, Grenoble, France (unpublished)] that this anomaly resulted from hyperfine coupling changes associated with the gradual supercritical change toward insulating behavior at high temperatures and thus is not directly related to the present investigation of the high-pressure metallic state.

¹⁴A. M. Clogston, A. C. Gossard, V. Jaccarino, and Y. Yafet, *Phys. Rev. Letters* **9**, 262 (1962).

¹⁵D. B. McWhan and J. P. Remeika, Paper I in this series, *Phys. Rev. B* **2**, 3734 (1970).

¹⁶Toshimoto Kushida and J. C. Murphy, *Phys. Rev.*

178, 433 (1969).

¹⁷Toshimoto Kushida and Lajos Rimai, *Phys. Rev.* **148**, 593 (1966).

¹⁸E. Fawcett and G. K. White, *Bull. Am. Phys. Soc.* **11**, 78 (1966); *Phys. Rev.* (to be published).

¹⁹J. Korringa, *Physica* **16**, 601 (1950).

²⁰N. Rivier and M. J. Zuckermann, *Phys. Rev. Letters* **21**, 904 (1968).

²¹M. D. Banus and T. B. Reed (unpublished).

²²W. W. Warren, A. C. Gossard, and M. D. Banus, *J. Appl. Phys.* **41**, 881 (1970).

²³F. J. Morin, *Phys. Rev. Letters* **3**, 34 (1959).

²⁴J. Umeda, S. Ashida, H. Kusumoto, and K. Narita, *J. Phys. Soc. Japan* **21**, 1461 (1966).

²⁵W. Rüdorff, G. Walter, and J. Stadler, *Z. Anorg. Allgem. Chem.* **297**, 1 (1958).

²⁶W. Kohn, *Phys. Rev. Letters* **19**, 789 (1967).

Observation of Nuclear Specific Heat in V_2O_3

K. Andres

Bell Telephone Laboratories, Murray Hill, New Jersey 07974

(Received 12 November 1969)

In an attempt to determine the magnetic moment of vanadium in the proposed antiferromagnetic state in insulating V_2O_3 , the nuclear specific heat has been measured in the temperature range below 0.5°K. A nuclear Schottky anomaly varying with T^{-2} is observed which indicates an over-all hyperfine splitting of 74 m°K and a hyperfine field of 168 kOe. Using a hyperfine coupling constant deduced by Jones from Knight-shift measurements in the metallic state of V_2O_3 , this hyperfine field is consistent with an ordered moment of $1.2 \mu_B$ per vanadium ion.

INTRODUCTION

Recent additional experimental information¹⁻³ on the metal-insulator transition of V_2O_3 has renewed the interest in this material and called for a reexamination of theoretical models regarding the driving force of this transition. Due to lack of evidence from magnetic susceptibility and neutron diffraction data, V_2O_3 has been considered for a long time to be nonmagnetic in its insulating state below the phase transition temperature of 150 °K. Jones⁴ first suggested an antiferromagnetic state since he observed the disappearance of the ⁵¹V NMR signal below 150 °K. Recent neutron scattering data now seem to indicate local moments of $1.2 \mu_B$ on the vanadium sites.⁵ To provide an independent determination of the ordered moment, we have measured the specific heat of V_2O_3 down to a temperature of 0.1 °K in order to search for a nuclear Schottky anomaly of the ⁵¹V nucleus ($I = \frac{7}{2}$, $g_n = 1.47$). We do indeed observe a nuclear Schottky anomaly which is consistent with an over-all hyperfine splitting of $k \cdot 74$ m°K, which would correspond to a nuclear-resonance frequency of 192 MHz. A splitting of the same order of mag-

nitude has recently also been observed by inelastic neutron scattering between the hyperfine levels of ⁵¹V in V_2O_3 .⁶ In Sec. I we briefly describe the experimental arrangement which we have used and in Sec. II we compare the result to other existing data on the magnetic properties of V_2O_3 .

I. EXPERIMENTAL DETAILS

The measurements were carried out in an adiabatic demagnetization cryostat in which powdered chromium potassium alum mixed with Apiezon grease and about 10³ No. 42 H. F. copper wires was used as a cooling salt. This salt, as well as a shield around it, is demagnetized from 30 kOe after it has been precooled to 0.5 °K through superconducting lead thermal switches by means of liquid He³. After demagnetization, the temperature of the salt (~12 m°K) can be maintained for about 1.5 h, the average stray heat leak during this time being about 2 erg/min. The sample consisted of 1.7 g of powdered (100 mesh) V_2O_3 which was in Apiezon grease contact with 800 No. 42 H. F. copper wires. These Cu wires were connected to the Cu wires of the salt pill through a superconducting tin thermal switch